

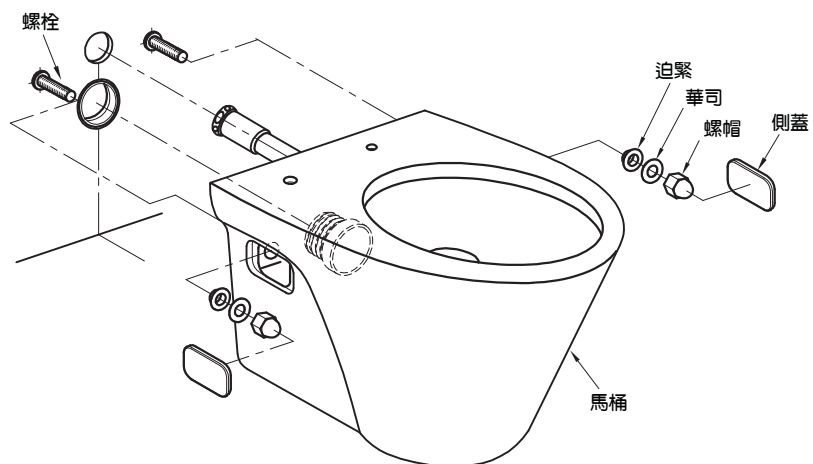

4

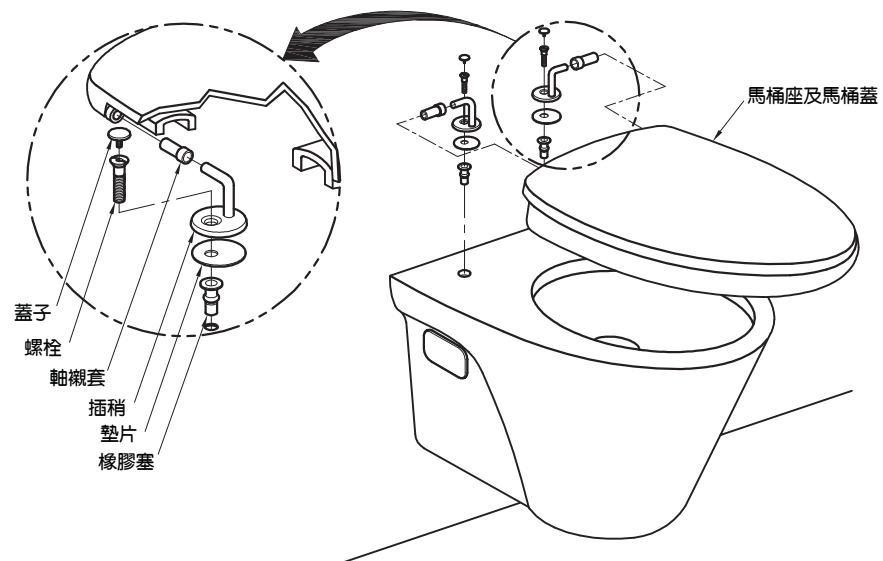

5



6

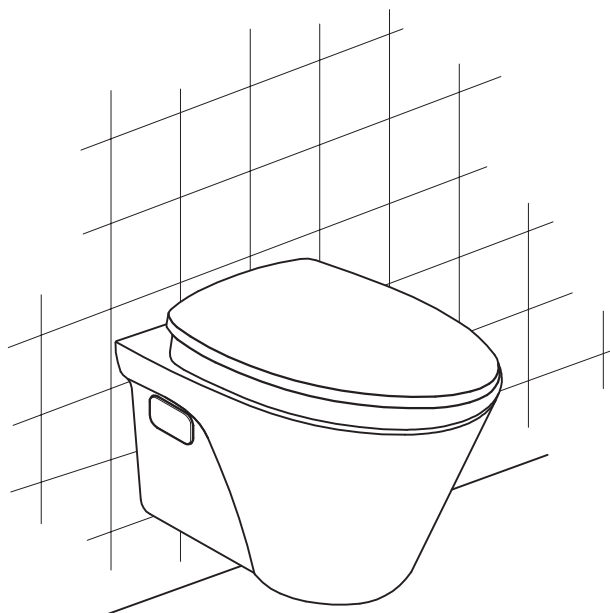

注意：「本安裝圖面僅供建議用，請與您當地之配管包商討論最佳的浴室配置，製造商及經銷商不擔負安裝之責任。」